

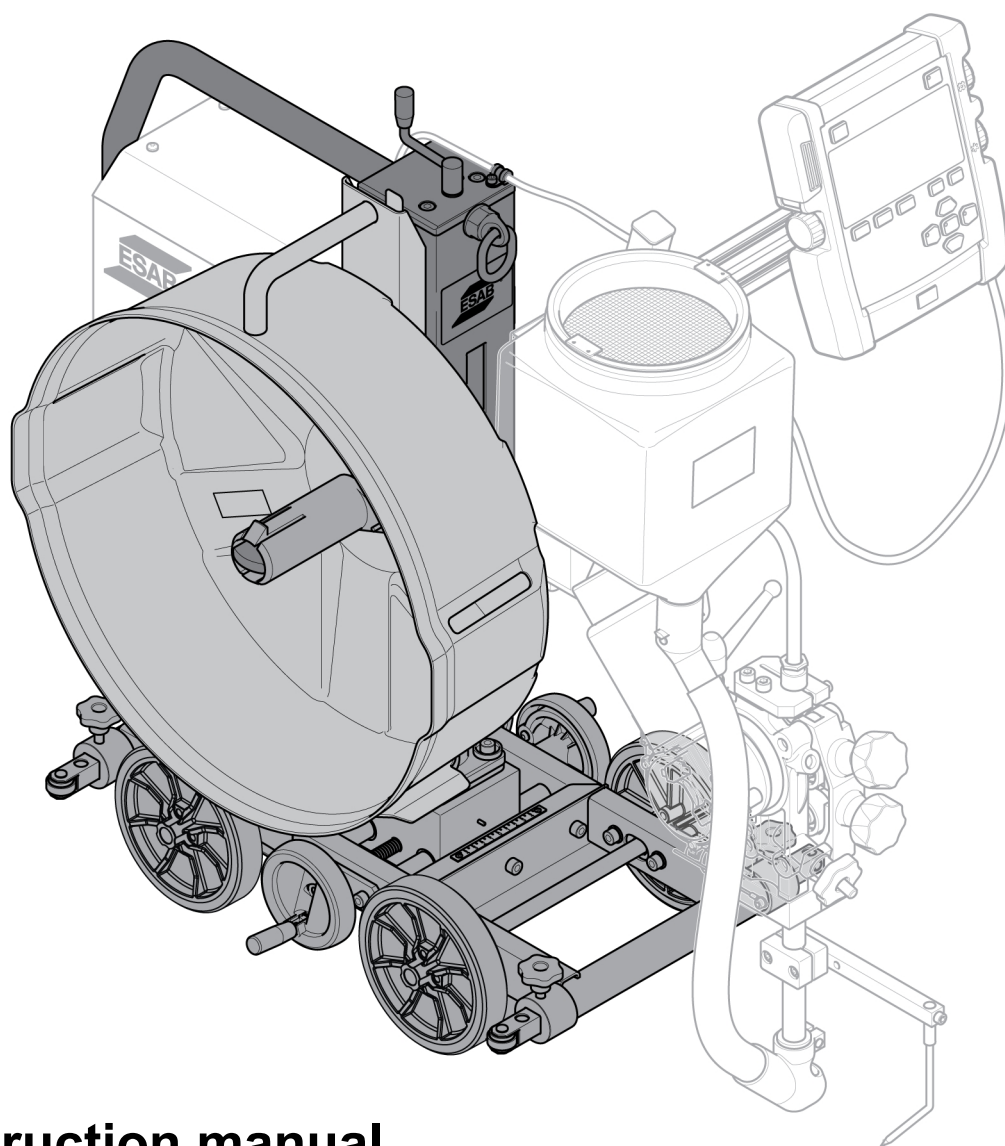

Versotrac EWT 1000 Chassis



Instruction manual
Original instructions



EU DECLARATION OF CONFORMITY

According to
The Machinery Directive 2006/42/EC, entering into force 29 December 2009
The Low Voltage Directive 2014/35/EU, entering into force 20 April 2016
The EMC Directive 2014/30/EU, entering into force 20 April 2016
The RoHS Directive 2011/65/EU, entering into force 2 January 2013

Type of equipment

Submerged arc welding tractor

Type designation

EWT 1000, 4 wheel drive unit,
EWT 1000, 3 wheel drive unit,

Serial number, from: 905 xxx xxxx,

Serial number, from: 905 xxx xxxx,

Brand name or trademark

ESAB

Manufacturer or his authorised representative established within the EEA

Name, address, and telephone no:

ESAB AB

Lindholmsallén 9, Box 8004, SE-402 77 Göteborg, Sweden

Phone: +46 31 50 90 00, www.esab.com

The following harmonised standard in force within the EEA has been used in the design:

EN 60974-5:2013,

Arc Welding Equipment – Part 5: Wire feeders

EN 60974-10:2014,

Arc Welding Equipment – Part 10: Electromagnetic compatibility (EMC) requirements

EN 12100:2010,

Safety of machinery – Risk assessment and risk reduction general principles for design

Additional Information:

Restrictive use, Class A equipment, intended for use in location other than residential

Flat fillet kit is optional

By signing this document, the undersigned declares as manufacturer, or the manufacturer's authorised representative established within the EEA, that the equipment in question complies with the safety requirements stated above.

Date

Gothenburg

2019-12-20

Signature

Peter Kjälström

Position

Automation Equipment Director

CE 2019

1	SAFETY	5
1.1	Meaning of symbols	5
1.2	Safety precautions	5
2	INTRODUCTION	9
2.1	Overview of complete tractor parts	9
2.2	Welding method	9
2.2.1	Definitions	9
2.2.2	Submerged Arc Welding (SAW)	9
2.2.3	GMAW (MIG/MAG) welding	10
2.3	Horizontal welding	10
2.4	Stability	10
3	TECHNICAL DATA	11
4	INSTALLATION	12
4.1	General	12
4.2	Lifting instructions	12
4.3	Assembly	13
4.3.1	Bobbin holder (optional)	13
4.3.2	Adjusting the brake hub	13
4.4	Connections	14
4.4.1	Connecting to digital power source	15
4.4.2	Connecting to compatible DC analogue power source	16
5	OPERATION	18
5.1	General	18
5.2	Main components	18
5.2.1	Welding cables	19
5.3	Transportation	19
5.4	The clutch	21
5.5	Changing to three wheeler module	22
5.6	Control panel EAC 10	23
5.6.1	Keys and knobs	23
5.6.2	Initial configuration	24
5.6.3	Startup	25
5.6.4	Measured screen	25
5.6.5	Set screen, digital power source	26
5.6.6	Set screen, analogue power source	27
5.6.7	Welding menu	27
5.7	Adjustments	28
5.8	Work piece voltage reference brush	28
5.9	Welding applications	30
6	MAINTENANCE	34
6.1	General	34

TABLE OF CONTENTS

6.2 Daily 34

6.3 Weekly 34

7 TROUBLESHOOTING 35

7.1 EWT 1000 35

7.2 EAC 10 35

8 ERROR CODES 36

9 ORDERING SPARE PARTS 38

DIAGRAM 39

ORDERING NUMBERS 41

ACCESSORIES 42

1 SAFETY

1.1 Meaning of symbols

As used throughout this manual: Means Attention! Be Alert!

**DANGER!**

Means immediate hazards which, if not avoided, will result in immediate, serious personal injury or loss of life.

**WARNING!**

Means potential hazards which could result in personal injury or loss of life.

**CAUTION!**

Means hazards which could result in minor personal injury.

**WARNING!**

Before use, read and understand the instruction manual and follow all labels, employer's safety practices and Safety Data Sheets (SDSs).



1.2 Safety precautions

Users of ESAB equipment have the ultimate responsibility for ensuring that anyone who works on or near the equipment observes all the relevant safety precautions. Safety precautions must meet the requirements that apply to this type of equipment. The following recommendations should be observed in addition to the standard regulations that apply to the workplace.

All work must be carried out by trained personnel well-acquainted with the operation of the equipment. Incorrect operation of the equipment may lead to hazardous situations which can result in injury to the operator and damage to the equipment.

1. Anyone who uses the equipment must be familiar with:
 - its operation
 - location of emergency stops
 - its function
 - relevant safety precautions
 - welding and cutting or other applicable operation of the equipment
2. The operator must ensure that:
 - no unauthorised person is stationed within the working area of the equipment when it is started up
 - no-one is unprotected when the arc is struck or work is started with the equipment
3. The workplace must:
 - be suitable for the purpose
 - be free from drafts

4. Personal safety equipment:
 - always wear recommended personal safety equipment, such as safety glasses, flame-proof clothing, safety gloves
 - do not wear loose-fitting items, such as scarves, bracelets, rings, etc., which could become trapped or cause burns
5. General precautions:
 - make sure the return cable is connected securely
 - work on high voltage equipment **may only be carried out by a qualified electrician**
 - appropriate fire extinguishing equipment must be clearly marked and close at hand
 - lubrication and maintenance must **not** be carried out on the equipment during operation

**WARNING!**

Arc welding and cutting can be injurious to yourself and others. Take precautions when welding and cutting.

**ELECTRIC SHOCK - Can kill**

- Install and ground the unit in accordance with instruction manual.
- Do not touch live electrical parts or electrodes with bare skin, wet gloves or wet clothing.
- Insulate yourself from work and ground.
- Ensure your working position is safe.

**ELECTRIC AND MAGNETIC FIELDS - Can be dangerous to health**

- Welders having pacemakers should consult their physician before welding. EMF may interfere with some pacemakers.
- Exposure to EMF may have other health effects which are unknown.
- Welders should use the following procedures to minimize exposure to EMF:
 - Route the electrode and work cables together on the same side of your body. Secure them with tape when possible. Do not place your body between the torch and work cables. Never coil the torch or work cable around your body. Keep welding power source and cables as far away from your body as possible.
 - Connect the work cable to the workpiece as close as possible to the area being welded.

**FUMES AND GASES - Can be dangerous to health**

- Keep your head out of the fumes.
- Use ventilation, extraction at the arc, or both, to take fumes and gases away from your breathing zone and the general area.

**ARC RAYS - Can injure eyes and burn skin**

- Protect your eyes and body. Use the correct welding screen and filter lens and wear protective clothing.
- Protect bystanders with suitable screens or curtains.

**NOISE - Excessive noise can damage hearing**

Protect your ears. Use earmuffs or other hearing protection.



MOVING PARTS - Can cause injuries

- Keep all doors, panels, guards, and covers closed and securely in place.
- Have only qualified people remove covers for maintenance and troubleshooting as necessary.
- Keep hands, hair, loose clothing and tools away from moving parts.
- Reinstall panels or covers and close doors when service is finished and before starting the unit.



FIRE HAZARD

- Sparks (spatter) can cause fire. Make sure that there are no inflammable materials nearby.
- Do not use on closed containers.



HOT SURFACE - Parts can burn

- Do not touch parts bare handed.
- Allow cooling period before working on equipment.
- To handle hot parts, use proper tools and/or insulated welding gloves to prevent burns.



CAUTION!

This product is solely intended for arc welding.



WARNING!

Do not use the power source for thawing frozen pipes.



CAUTION!

Class A equipment is not intended for use in residential locations where the electrical power is provided by the public low-voltage supply system. There may be potential difficulties in ensuring electromagnetic compatibility of class A equipment in those locations, due to conducted as well as radiated disturbances.

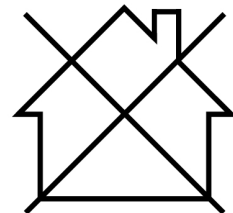

NOTE!

Dispose of electronic equipment at the recycling facility!

In observance of European Directive 2012/19/EC on Waste Electrical and Electronic Equipment and its implementation in accordance with national law, electrical and/or electronic equipment that has reached the end of its life must be disposed of at a recycling facility.

As the person responsible for the equipment, it is your responsibility to obtain information on approved collection stations.

For further information contact the nearest ESAB dealer.



ESAB has an assortment of welding accessories and personal protection equipment for purchase. For ordering information contact your local ESAB dealer or visit us on our website.

2 INTRODUCTION

The **Versotrac EWT 1000** welding equipment is designed for **Submerged Arc Welding (SAW)** and **GMAW (MIG/MAG) welding** of butt and fillet joints.

All other applications are prohibited.

The equipment is intended for use in combination with ESAB control system **EAC 10**, ESAB welding heads **EWH** and ESAB digital power sources **LAF xxx1**, **TAF xxx1** or **Aristo 1000** and through the analogue interface also **LAF 635** and **LAF 1000**.

The **EAC 10** also supports analogue controlled power sources from other suppliers, see chapter "Connecting to compatible DC analogue power source" for more information about the interface.

2.1 Overview of complete tractor parts

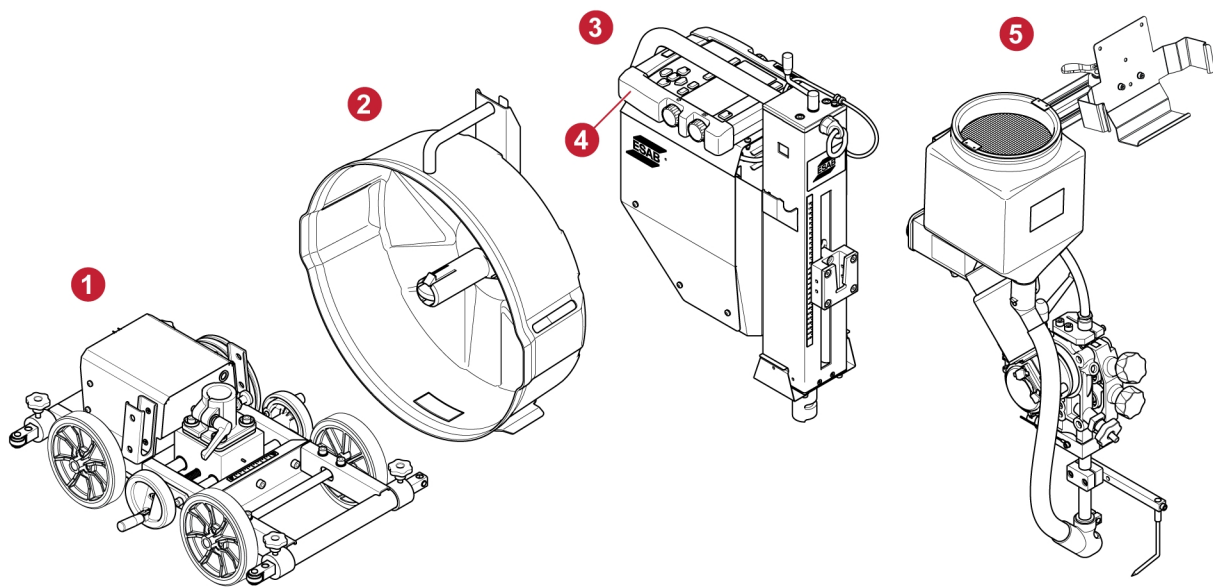

- | | |
|-----------------------|----------------------------|
| 1. Tractor carriage | 4. EAC 10, control pendant |
| 2. Bobbin holder | 5. EWH 1000, welding head |
| 3. Column with EAC 10 | |

2.2 Welding method

2.2.1 Definitions

SAW	The weld bead is protected by a cover of flux during the welding.
GMAW (MIG/MAG) welding	The weld bead is protected by shielding gas during welding.
Twin wire welding	Welding with two wires in one torch.
Flat fillet welding	Welding in downhand position, on the top side of the joint.

2.2.2 Submerged Arc Welding (SAW)

Use **EWH 1000 Single** or **EWH 1000 Twin** welding equipment for Submerged Arc Welding. EWH 1000 permits loads up to 1000 A (100%).

This version can be equipped with feed rollers for single or twin wire welding (twin-arc). A special knurled feed roller is available for flux-cored wire, which guarantees even wire feed without the risk of deformation of welding wire due to high feed pressure.

2.2.3 GMAW (MIG/MAG) welding

For GMAW (MIG/MAG) welding use welding equipment **EWH 600 GMAW**.

EWH 600 GMAW consists of a GMAW torch and gas shielding equipment.

The welding head is water-cooled. The cooling water is supplied by hoses from connections intended for the purpose.

2.3 Horizontal welding

The product described in this manual is designed for horizontal welding. The welding tractor can be used for flat fillet welding when welding a tilted fillet joint with the optional flat fillet welding kit.



NOTE!

Do not use **EWT 1000** when welding on inclined planes.

Avoid welding on surfaces with a slope greater than 3° (>5 cm/m) due to risk of weld defects caused by the large size of the melted metal in the weld pool.

2.4 Stability



NOTE!

Always check the welding equipment for stability before welding.

The EWT 1000 is designed to be flexible and cover many different welding applications and setups. The stability can be improved by moving the horizontal slide, moving wire bobbin to opposite side, etc.

3 TECHNICAL DATA

Versotrac EWT 1000 Chassis with EAC 10 control unit, from serial no. 905-xxx-xxxx and LX905-xxxx-xxxx	
	EWT 1000 & EAC 10
Supply voltage	60 V DC or 42 V AC, 50/60 Hz
Max power requirement	900 VA
Supply voltage to control pendant	12 V DC
Travel speed	0.1–2.0 m/min (0.3–6.6 feet/min)
Speed control	Feedback from pulse encoder
Brake hub braking torque	1.5 Nm (13.3 in. lb)
Minimum turning radius for circumferential welding	
Inside object diameter	3000 mm (9 ft 10.11 in.)
Outside object diameter, four wheels	3900 mm (12 ft 9.54 in.)
Minimum pipe diameter for internal joint welding	1100 mm (3 ft 7.31 in.)
Maximum weight of wire	30 kg (66 lb)
Weight	
Total, excluding wire and flux	67 kg (148 lb)
Tractor carriage and EAC 10	45 kg (99 lb)
Bobbin holder, without wire	6 kg
Relative air humidity	Max 95%
Operating temperature	-10 to +40 °C (-14 to +104 °F)
Storage temperature	-20 to +55 °C (-4 to +131 °F)
Maximum surface temperature on weld object (wheel)	150 °C
EMC classification	Class A
Enclosure class tractor carriage	IPXX
Enclosure class control unit	IP23

4 INSTALLATION

4.1 General

The installation must be carried out by a professional.



WARNING!

Rotating parts can cause injury, take great care.



CAUTION!

This product is intended for industrial use. In a domestic environment this product may cause radio interference. It is the user's responsibility to take adequate precautions.

4.2 Lifting instructions

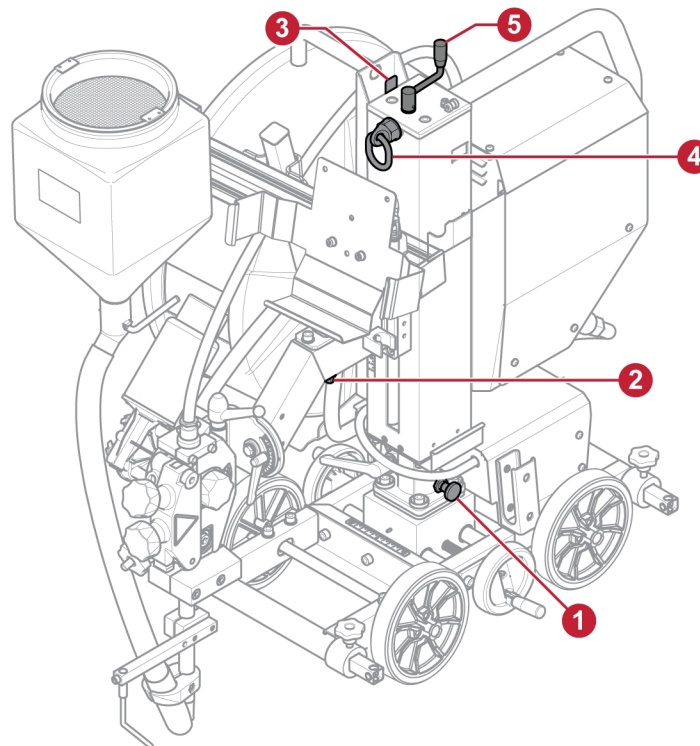

WARNING!

The welding tractor must be lifted using the lifting eye (4).

- Disconnect the power source and remove all consumables (flux and welding wire).
- Disconnect and remove welding cables from the welding tractor. The welding cables are not to be lifted with the tractor.
- Remove optional air and water hoses.
- Make sure the column is in locked position (1), directed forward as shown in illustration.

- Make sure the welding head arm is in locked position (2).
- Remove bobbin holder or remove wire drum from bobbin holder. Make sure that the empty bobbin holder is in locked position (3).
- Make sure that the crank, for height adjustment (5), is turned away from the lifting eye (4).

4.3 Assembly

For information about assembly of the welding tractor, see chapter "Transportation".

4.3.1 Bobbin holder (optional)

Mount the wire drum on the brake hub in the bobbin holder.

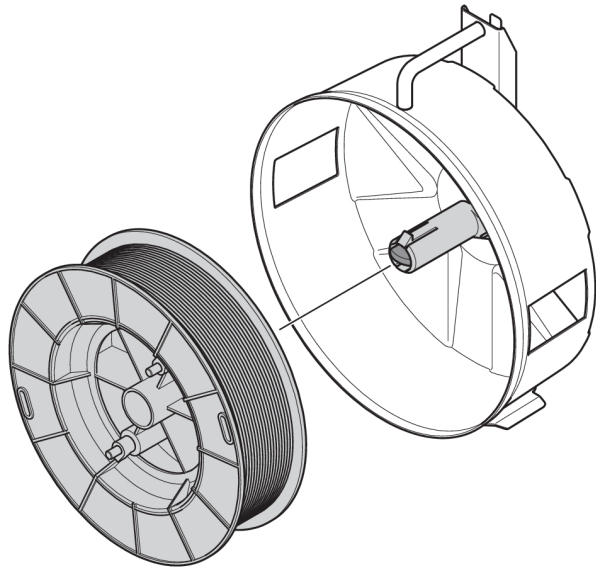

WARNING!

To prevent the reel from sliding off the hub: Lock the reel in place by turning the red knob as shown on the warning label attached next to the hub.

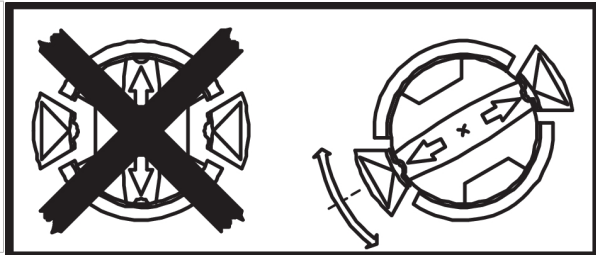

4.3.2 Adjusting the brake hub

The brake hub is adjusted at delivery. If readjustment is required, follow the instructions below. Adjust the brake hub so the wire is slightly slack when wire feed stops.

Adjusting the braking torque:

1. Turn the red handle to the locked position.
2. Insert a screwdriver into the springs in the hub.
 - Turn the springs clockwise to reduce the braking torque.
 - Turn the springs counter-clockwise to increase the braking torque.

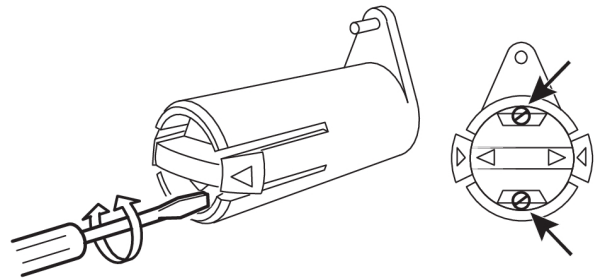

NOTE!

Turn both springs the same amount.

4.4 Connections

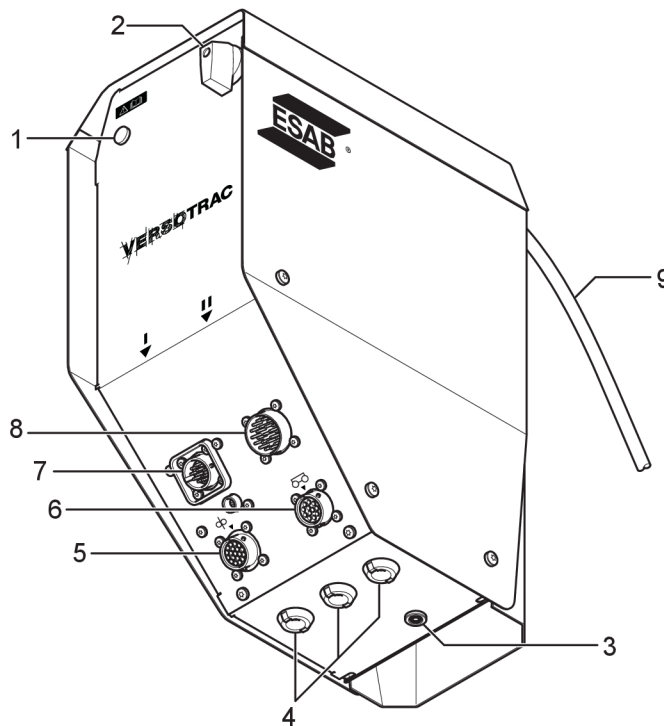

- | | |
|--|-------------------------------------|
| 1. On/Off indicator | 6. Connection tractor carriage |
| 2. On/Off switch | 7. Connection digital power source |
| 3. Connection work piece voltage reference brush | 8. Connection analogue power source |
| 4. Accessory cable entries | 9. Cable to control pendant |
| 5. Connection welding head | |



NOTE!

Connect only digital power source **or** analogue power source at a time.

4.4.1 Connecting to digital power source

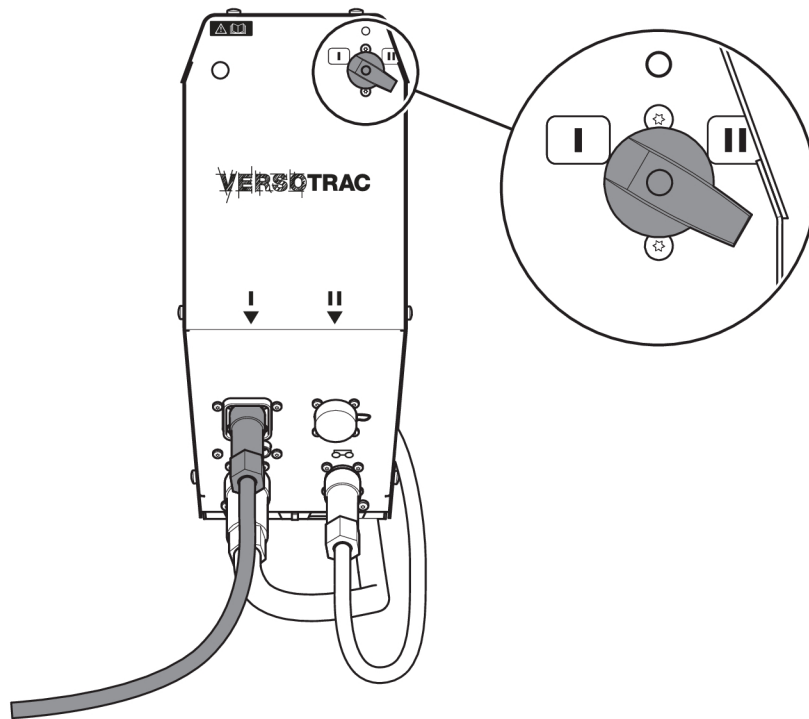

Connect the interconnection cable to connector marked with I.

Interconnection cable between CAN based ESAB power source and EAC 10 are available as accessories in different lengths.

ESAB CAN based power sources are LAF xxx1, TAF xxx1 and Aristo® 1000.

For further information about connecting welding power source, see separate instruction manual.

Always use the dust cover on the connections where no cable is connected.

4.4.2 Connecting to compatible DC analogue power source

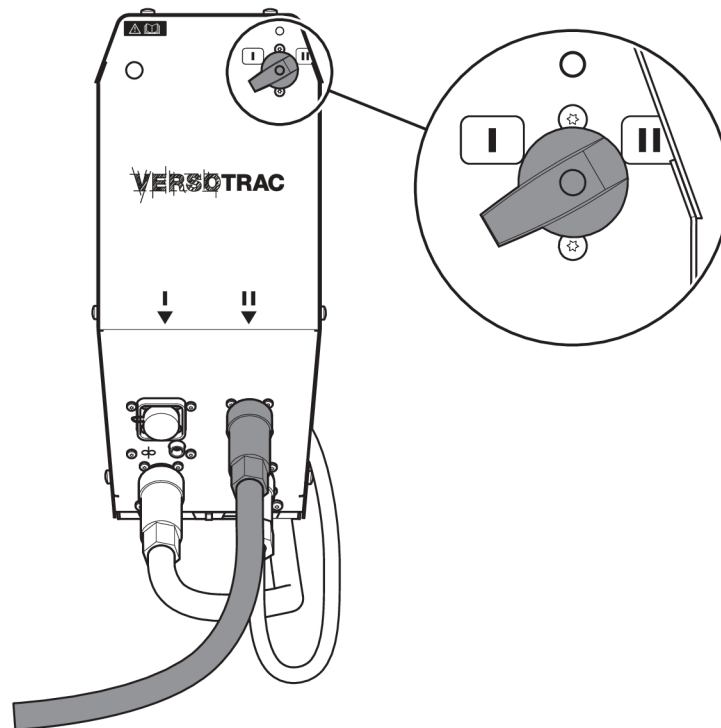

Connect the interconnection cable to connector marked with **II**.

Interconnection cable between analogue based ESAB power source and EAC 10 control unit are available as accessories in different lengths.

Always use the dust cover on the connections where no cable is connected.

Requirements on the analogue power source

- Supply voltage 60 V DC or 42 V AC, 50/60 Hz from welding power source or by external means.
- Voltage feedback from negative welding terminal (for welding voltage measurement for display in pendant).
- Start input to initiate welding, analogue input (0–10 V DC) for setting welding parameter (control signal).
- 1000 A/60 mV shunt output for welding current measurement.

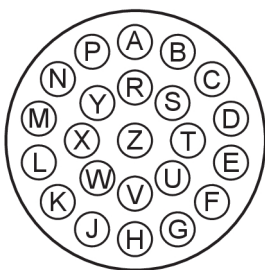

Power source connection socket XP2 pinouts	
B, C	42 V AC
E, F	42 V AC return
J	Power source negative terminal (U-)
W	Power source positive terminal (U+)

Power source connection socket XP2 pinouts	
X	Arc voltage from welding head
K	Power source start
L	0 V, common for power source start and reference
M	0-10 V reference
N	Current shunt negative (-mV)
P	Current shunt positive (+mV)
R	Emergency stop
Y	Emergency stop
S	24 V AC / trigger input. For non-ESAB power sources.
T	Contact closure to pin S / trigger common. For non-ESAB power sources.
U	Reserved for future use.

To connect EAC 10 with non-ESAB SAW analogue power source, an analogue power source interface box and control cables are available as accessories.

See chapter "ACCESSORIES".

5 OPERATION

5.1 General



CAUTION!

Read and understand the instruction manual before installing or operating.



General safety regulations for handling the equipment can be found in the "SAFETY" chapter of this manual. Read it through before you start using the equipment!



NOTE!

When moving the equipment use intended handle. Never pull the cables.



NOTE!

The tractor is supplied with a strap. It can be used to collect the welding cables behind the tractor.

5.2 Main components

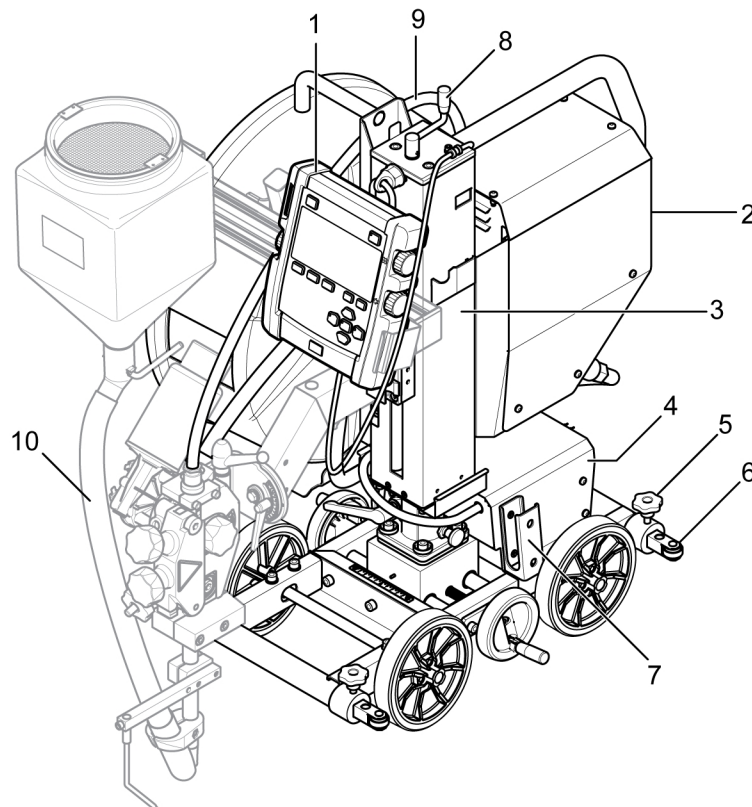

- | | |
|----------------------------|---|
| 1. EAC 10 Control pendant | 6. Guide bar |
| 2. EAC 10 Motor drive unit | 7. Cable support |
| 3. Column | 8. Crank, for height adjustment |
| 4. Tractor carriage | 9. Wire liner |
| 5. Guide bar lock | 10. Welding head (optional) - not part of
Versotrac EWT 1000 Chassis |

5.2.1 Welding cables

Use different welding cables for different welding currents:

Up to 500 A	two 95 mm ² cables (one on each side of the tractor)
500 - 1000 A	two 120 mm ² cables (one on each side of the tractor)

**NOTE!**

With two welding cable setup, run the welding cables close to each other in parallel, but do not twist them around each other.

5.3 Transportation

It is possible to transport the fully assembled Versotrac EWT 1000 welding tractor or the Versotrac EWT 1000 Chassis only by following the instructions in section "Lifting instructions".

Follow these instructions to dismantle the fully assembled Versotrac EWT 1000 welding tractor into four separate modules before transportation.

When transporting the welding tractor EWT 1000 on the wheels: place the horizontal slide in the middle position with the needle pointing to zero on the scale.

**NOTE!**

Make sure the welding head has cooled down before dismantling.

1. Turn off and disconnect the power source. Disconnect the cables to the welding head and the tractor carriage (1). Remove the cables from the welding tractor.

**NOTE!**

If the power source is disconnected without turning off power first, the power source emergency stop can be activated.

2. Remove wire from wire feed unit and wire liner (2).
3. Unlock and dismantle the bobbin holder (3).
4. Place the EAC 10 control pendant on the top of the EAC 10 motor drive unit.
5. Make sure the column is positioned in the middle of the tractor carriage.
6. Unlock and dismantle the welding head (4).
7. Disconnect the cable (5) between the tractor carriage and the control unit.
8. Unlock the column rotation with the handle (6). Rotate to end point. Pull (7) and rotate a few more degrees. Dismantle the control unit (8).
9. Reassemble in backwards order. Make sure to lock the welding head (6).

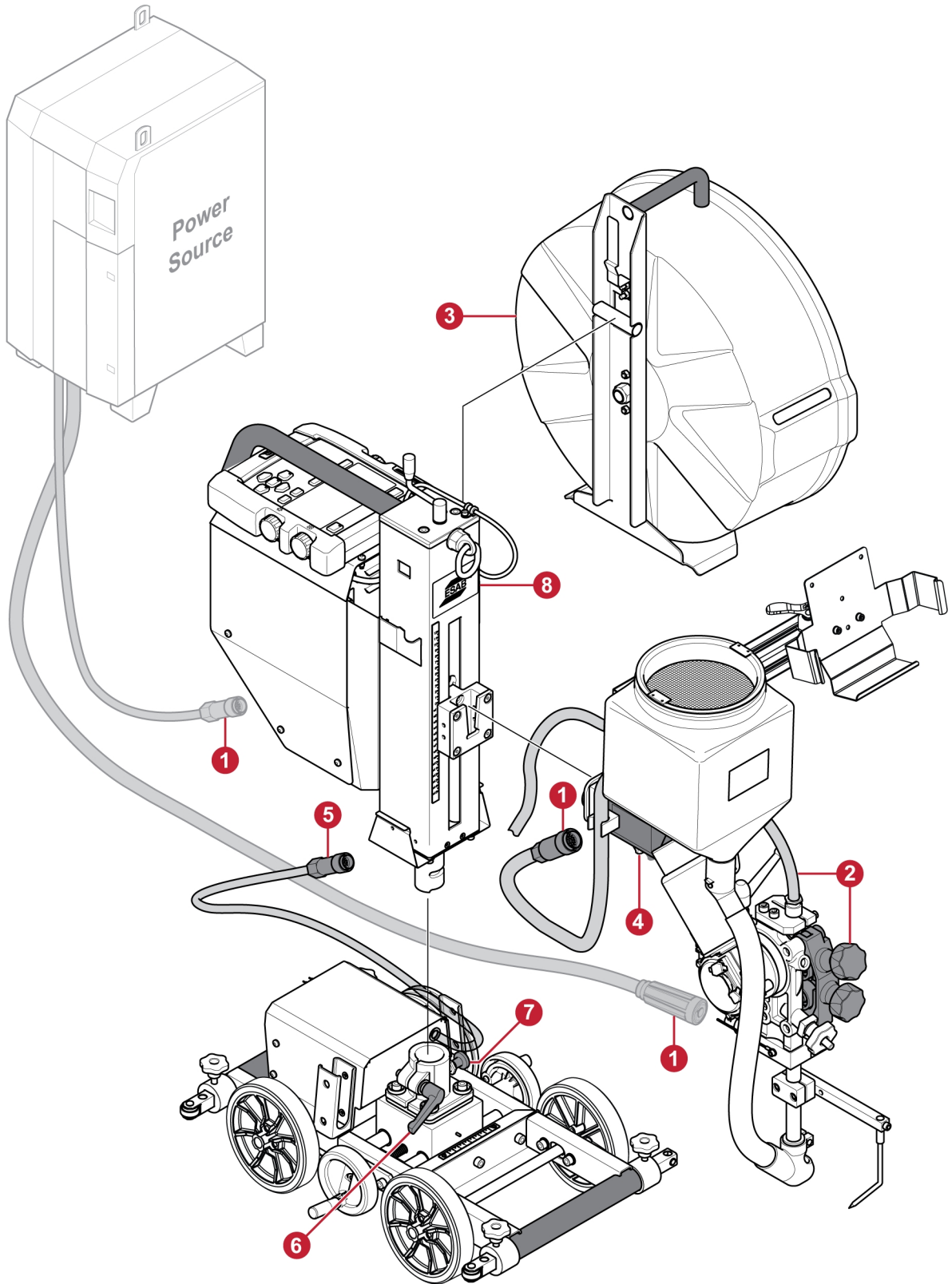

5.4 The clutch

Use the clutch knob in the back of the tractor carriage to lock and unlock the wheels from the motor. The wheels will be engaged with the motor when in locked position.

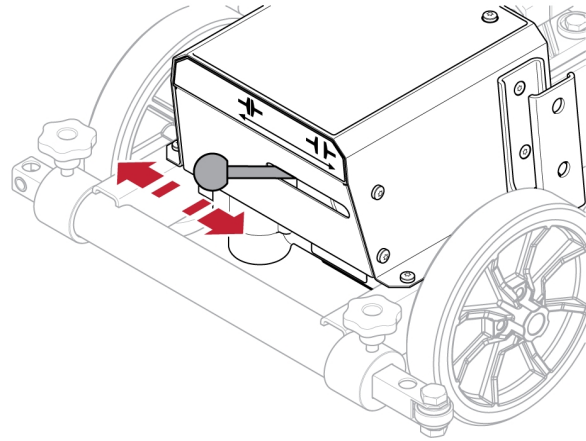

5.5 Changing to three wheeler module

1. Dismount the welding tractor according to the instructions in chapter "Transportation".

To prevent overturning, place a support block under the welding tractor before removing the front wheels.

Remove the three screws holding the front wheels.

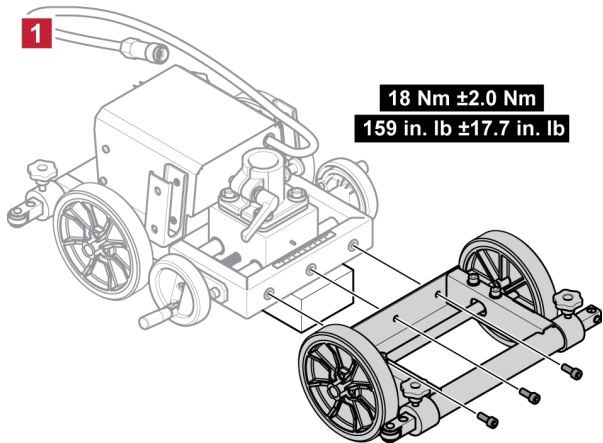

2. Assemble the bracket using the three screws.

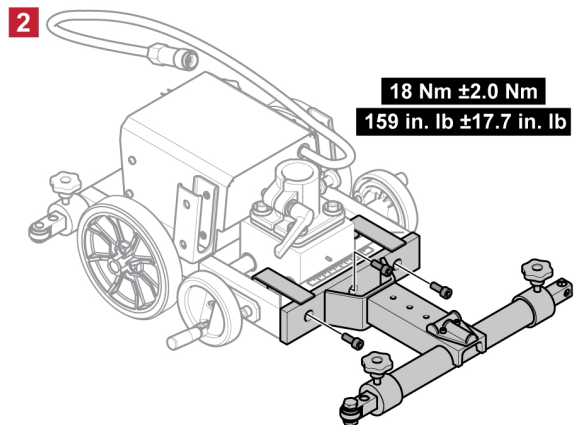

3. Slide the three wheel kit onto the bracket.
Lock into position with the two screws.
Change back to four wheels following these steps in backwards order.

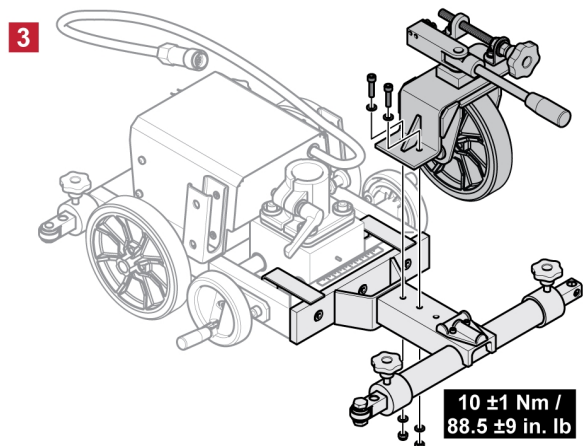

5.6 Control panel EAC 10

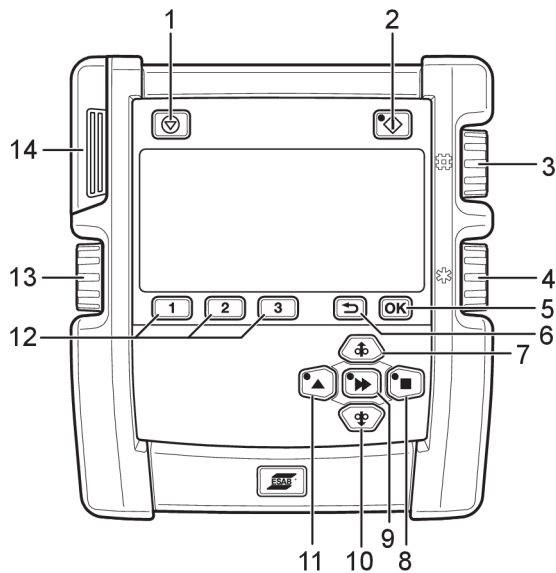

- | | |
|---|------------------------------------|
| 1. Welding stop | 8. Manual travel motion direction |
| 2. Welding start | 9. Fast motion |
| 3. Welding current / Wire feed speed/balance* | 10. Manual wire feed downwards |
| 4. Arc voltage / Offset voltage* | 11. Manual travel motion direction |
| 5. OK / Setting menu | 12. Memory 1, 2, 3 / Soft keys |
| 6. Back | 13. Travel speed / frequency* |
| 7. Manual wire feed upwards | 14. USB connection |

*Only with Aristo® 1000 in AC mode.

5.6.1 Keys and knobs

The buttons are used for Up, Down, Right, Left and Confirm (middle button) during configuration and setting.

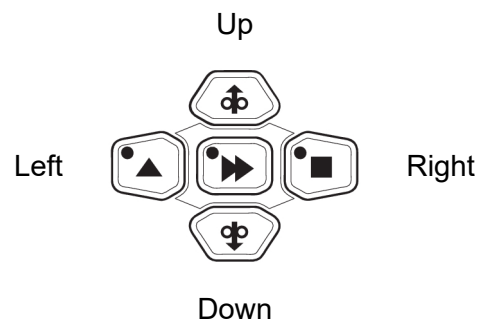

Welding stop (1). Stops all travel motions, all motors and welding current.



Welding start (2). The LED is lit when welding is in progress.



The **OK** button (5) is used to confirm a selected choice.



The **Back** button (6) is used to go back one step into the menu. To set wire type and wire dimension, press and hold for more than 3 seconds.



Press **Manual wire feed upwards** button (7) to feed the wire upwards. The wire is fed as long as the button is pressed.



Press **Travel motion** (8) button to drive in the direction of welding where the symbol is indicated on the weld equipment.



Fast motion button (9) is used together with other buttons to increase speed. Press the button to activate fast motion and then press manual wire feed (7, 10) or travel motion (8, 11) button. The LED on the fast motion button is lit while fast motion is activated. Press again to deactivate fast motion. During configuration, it is possible to confirm and save a value and return to previous screen using the Fast motion button.



Press **Manual wire feed downwards** button (10) to feed the wire downwards. The wire is fed as long as the button is pressed.



Press **Travel motion** (11) button to drive in the direction of welding where the symbol is indicated on the weld equipment.



Three different welding data memories per welding head can be stored in the control panel memory using the soft keys 1, 2 and 3 (12). The soft keys have also varying functions depending on which menu currently is in use. The current function can be seen from the text in the bottom row of the display.



The welding current / wire feed speed/balance knob¹ (3) is used for increasing or decreasing set values.



The arc voltage / offset voltage knob¹ (4) is used for increasing or decreasing set values.



The travel speed/frequency knob¹ (13) is used for increasing or decreasing set values.

¹ Only with Aristo® 1000 in AC mode.

5.6.2 Initial configuration

At first startup after delivery, after a program update and after a completed reset, the control panel requires initial configuration. The initial configuration starts automatically.

Initial configuration can also be initiated by pressing and holding *OK* during startup, while the ESAB logo is shown.

It is possible for an authorised user to change the configuration in the *GENERAL SETTINGS* menu.

1. Select language using the Up/Down/Right/Left buttons. Confirm with *OK* or with the middle button.
2. Select measurement unit using the Right/Left buttons. Confirm with *OK* or with the middle button.
3. Set date using the Up/Down buttons. Change between year, month and day with the Right/Left buttons. Confirm with *OK* or with the middle button.
4. Set time using the Up/Down buttons. Change between hours and minutes with the Right/Left buttons. Confirm with *OK* or with the middle button.
5. Select wire type using the Up/Down buttons. The wire types shown depend on the welding head detected during startup. Confirm with *OK* or with the middle button.
6. Select wire dimension using the Up/Down buttons. Confirm with *OK* or with the middle button.
7. After initial configuration, the control panel continues to the *SET* menu.

5.6.3 Startup



1. The software version is shown on the control panel during startup. The control panel automatically detects the welding head during startup.



NOTE!

The welding head is identified by the welding head cable. If the cable is replaced, use ESAB original spare part to maintain the feature.

2. If no digital power source is attached, a menu for selecting type of analogue power source is shown.
Previously used analogue power source is shown if on/off switch is in position II. Press any button within 3 seconds to open the menu and change analogue power source using the buttons Up/Down and OK.
If no button is pressed, the startup will proceed with no changes on power source.
3. Previously selected wire type and wire dimension is shown. Press any button within 7 seconds to open the menu. Select wire type and wire dimension using the buttons Up/Down and OK.
If no button is pressed, the control panel continues to the *SET* menu with no changes on wire type or wire dimension.

5.6.4 Measured screen

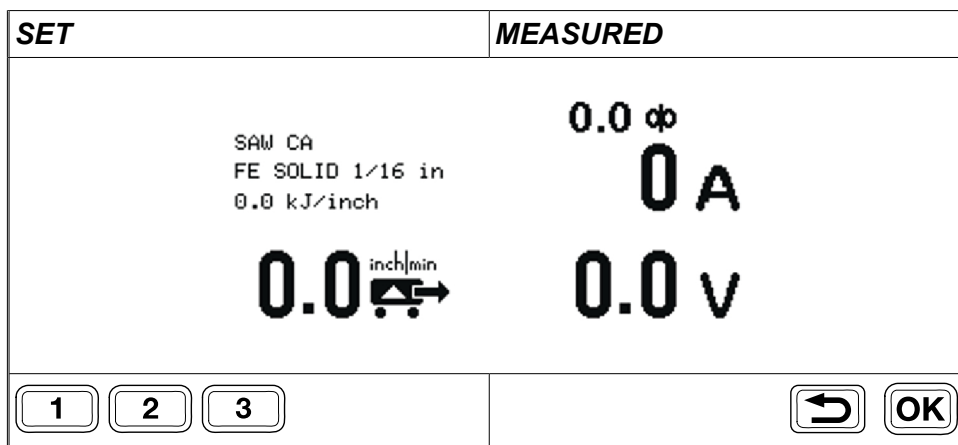

The *MEASURED* screen shows the measured values during welding. The information on the screen depends on the selected welding method.

The screen shows information divided into four parts:

Method, wire, heat input	Amperage
Travel speed	Voltage

 A short press on *OK* when an AC power source is connected will open the AC settings screen. A long press on *OK* opens the *WELDING MENU* settings screen. Turn any of the knobs after welding stop to open the *SET* screen. The values are shown and the *SET* screen is kept open.

 A short press on any of the keys 1, 2, or 3 recalls the corresponding memory slot. The *SET* screen is opened and the values are displayed.

5.6.5 Set screen, digital power source



NOTE!

The available functions of the *SET* screen depends on selected welding method.

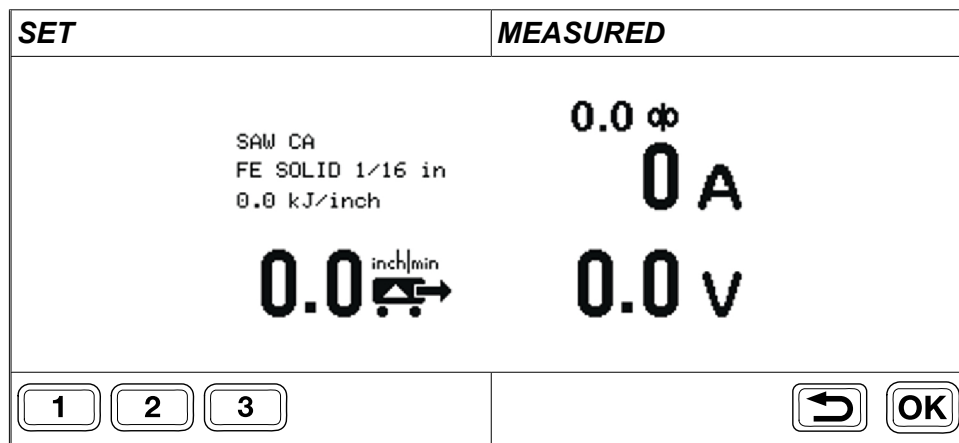



The *SET* screen is used to change welding settings and save settings to the memory slots using the keys 1, 2 and 3.

Turn any of the knobs during welding to open the *SET* screen from the *MEASURED* screen. The values are shown during 2 seconds before returning to the *MEASURED* screen unless any adjustments are made.

If the *SET* screen is opened without ongoing welding, it will stay active. When welding starts, the *MEASURED* screen is activated.

Change the welding settings by using the knob next to the value shown on the display. It is possible to save the settings for easy access.

 A short press on any of the keys 1, 2 or 3 will display the saved welding data memory settings, set the values and show the the *MEASURED* screen again. The welding data memory number in use is shown on the *SET* tab and also with a bar above the key with the corresponding number.

 With AC power source: A short press on the *OK* button opens the *AC SETTINGS* screen.

 A long press on the *OK* button opens the *WELDING MENU*. Return by pressing the *Back* button. To set wire type and wire dimension, press and hold the *Back* button for more than 3 seconds.

5.6.6 Set screen, analogue power source

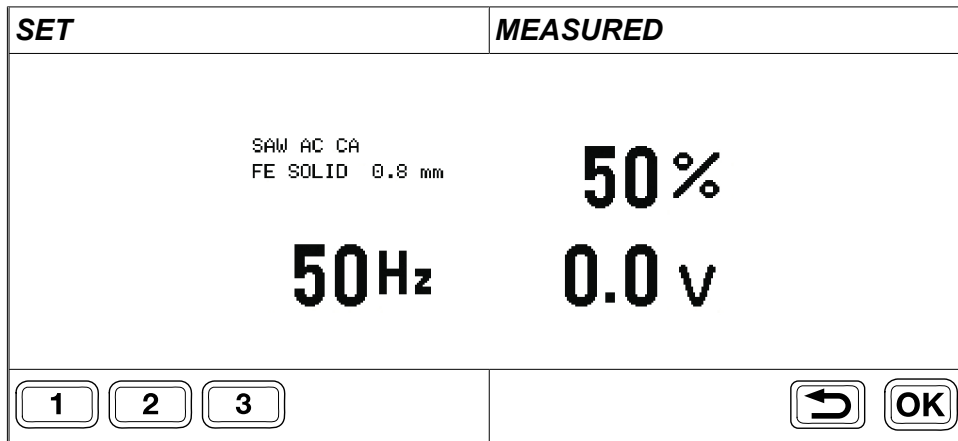

With AC power source: A short press on the OK button opens the *AC SETTINGS* screen.

With Aristo® 1000 power source and SAW welding head: A short press on the OK button opens a screen where the knobs will control frequency, balance and offset.



Save values and return to the *MEASURE* screen by pressing the Back button.

5.6.7 Welding menu



When any of the screens *SET* or *MEASURED* is shown, press long on OK to open the extended *WELDING MENU*.

The information on the display depends on the authorisation level, attached power source and welding head. The authorisation level is shown with an icon in the upper right corner of the display.

Example of welding menu for Aristo® 1000 AC/DC		
	WELDING MENU	
	<i>METHOD</i>	<i>DC+</i>
	<i>REGULATION TYPE</i>	<i>CA</i>
	<i>START TYPE</i>	<i>DIRECT</i>
	<i>CRATER FILL TIME</i>	<i>0.0 s</i>
	<i>BURNBACK TIME</i>	<i>0.50 s</i>

Example of welding menu for SAW welding with LAF or TAF		
	WELDING MENU	
	<i>REGULATION TYPE</i>	<i>CA</i>
	<i>START TYPE</i>	<i>DIRECT</i>
	<i>CRATER FILL TIME</i>	<i>0.0 s</i>
	<i>BURNBACK TIME</i>	<i>0.7 s</i>



Select the *WELDING MENU* by pressing the Right button.



Select a menu row using the Up/Down buttons and press OK or confirm with the middle button.



Set a numerical value using the Arc voltage / Offset voltage knob (4). Other values are selected using the Up and Down buttons.



Press OK or the Middle button to confirm and return to the previous menu level. The new value is displayed.



Return to previous menu level **WITHOUT** changed settings with Back or the Left button.



5.7 Adjustments

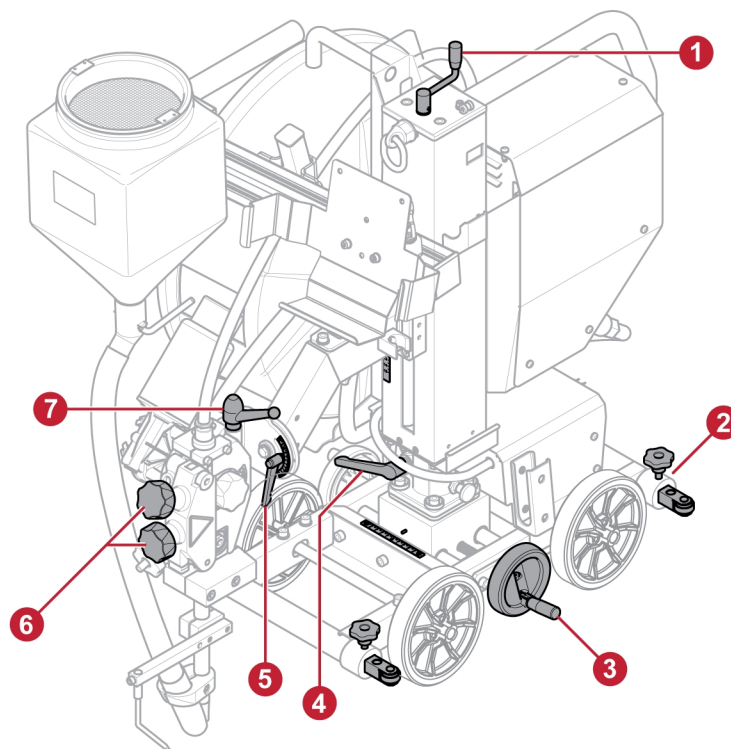

NOTE!

Always keep handle in locked position when not adjusting.

1. Vertical adjustment of the welding head, see scale on the column.
2. Adjust the guide roller device distance, both in front and back of welding tractor.
3. Adjust the horizontal column location, see scale next to the column.
4. Adjust the rotation angle of the column.
5. Adjust the rotation angle of the welding head, see scale next to handle.
6. Adjust the wire pressure.
7. Adjust the rotation angle of the welding head.

5.8 Work piece voltage reference brush

The Versotrac offers an alternative work piece voltage reference through a mounted brush. The work piece voltage reference brush provides a stable work piece voltage reference for the welding power source. The solution effectively eliminates disturbance in the arc voltage measuring cables by providing a more stable welding arc.

This is the recommended solution for work piece reference when welding with an AC power source with Versotrac.

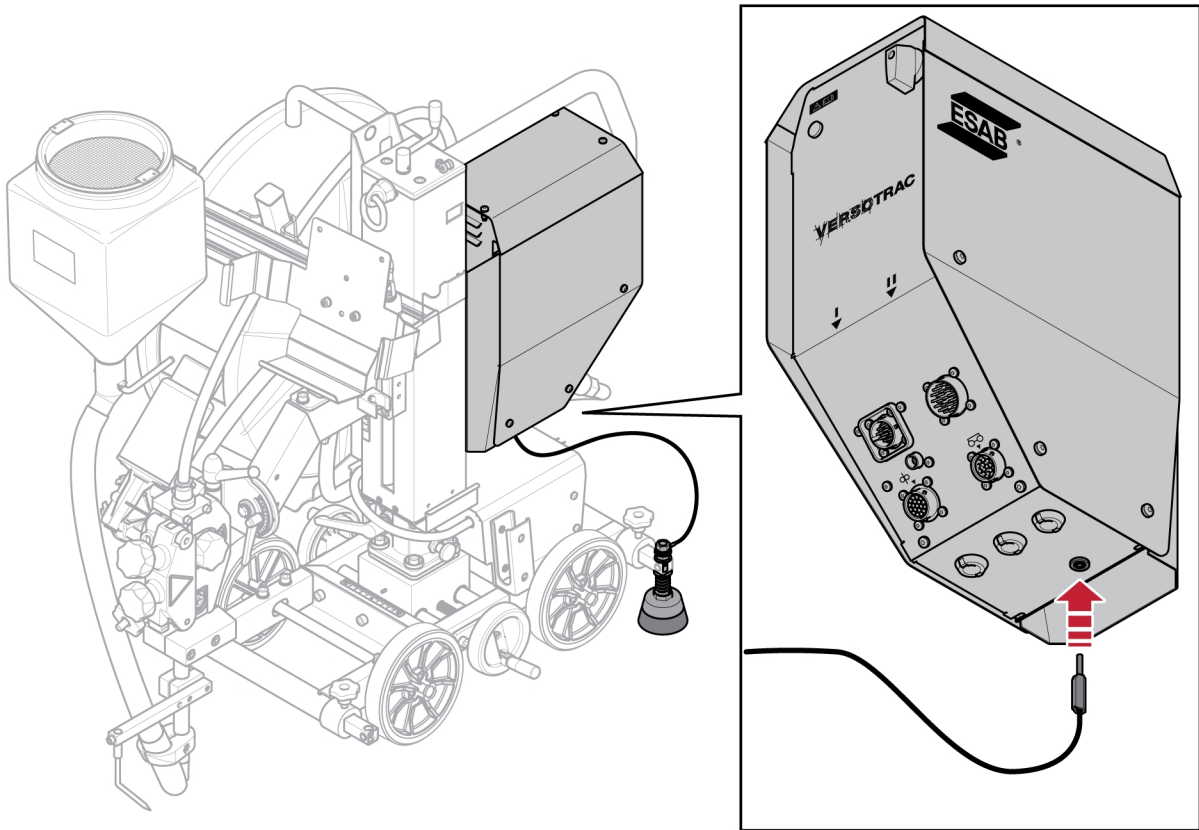

Mount the work piece voltage reference brush on any of the guide bars.

Connect the cable into the work piece voltage reference input on the control unit EAC 10.



NOTE!

Control cable 0446 146 880-885 is required between the control unit EAC 10 and the power source. See chapter "ACCESSORIES".

5.9 Welding applications

Basic version

EWT 1000 in basic version with guide roller device. This positions the welding tractor correctly along fillet welds with the driving wheels angled about $0.5\text{--}1^\circ$ in towards the vertical plate and with guide roller device steering along a guide parallel to the joint. The guide may be part of the workpiece or a separate guide rail that has been aligned parallel to the joint.

Circular fillet welding. The welding tractor follows the joint using the basic guide arm device. Minimum radius 3.9 m.

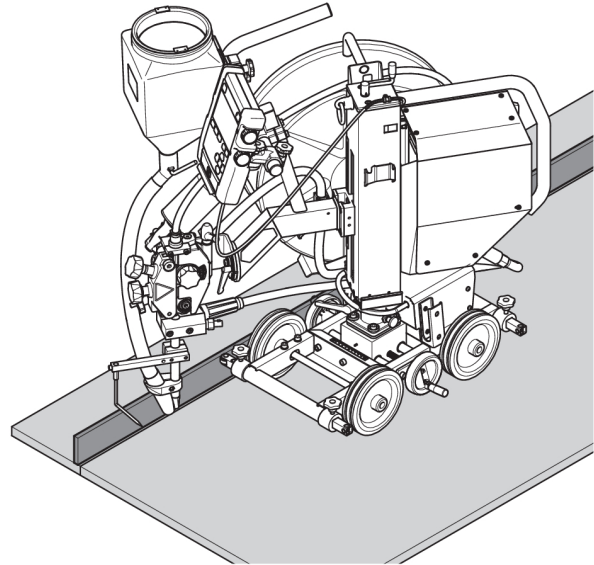

Idling rollers (0446 151 880)

Idling rollers with adjustable height are supplied as an accessory. Two idling rollers are required when fillet welding along a low vertical plate. The idling rollers can also be used for various types of workpieces, for example along guide edges parallel to the weld joint.

See chapter "ACCESSORIES".

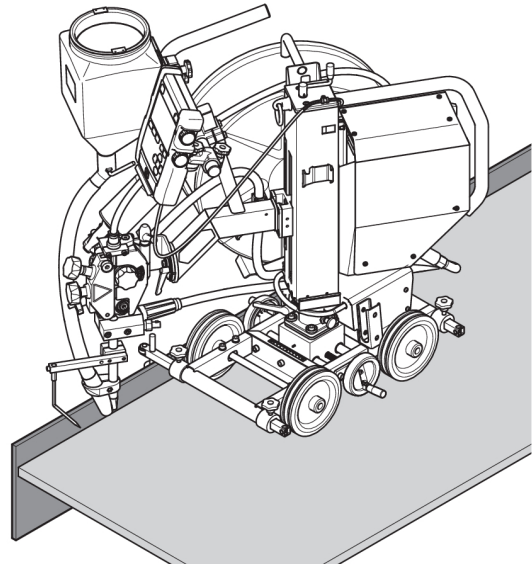

Laser lamp (0821 440 880)

If there is no suitable edge along which to steer the welding tractor mechanically, for example when making an I-joint, the laser lamp will be helpful with submerged-arc welding in order to indicate the position of the welding nozzle in the joint. See chapter "ACCESSORIES".

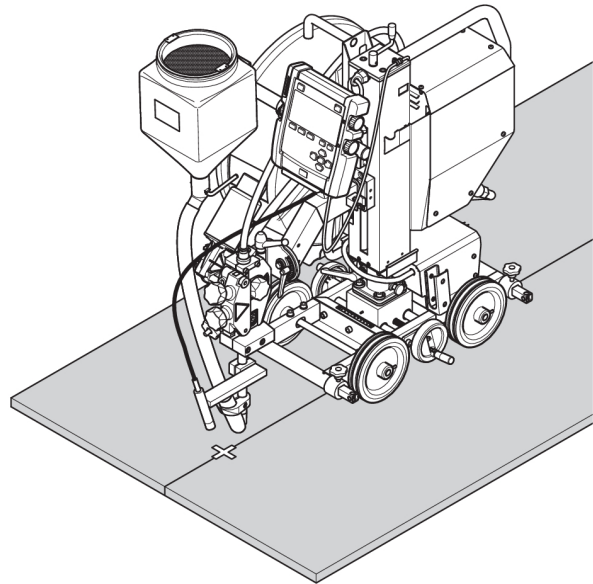

Guide wheel bogey (0413 542 880)

Use of the guide wheel bogey in a V-joint allows the welding tractor to track the joint. The welding tractor can pass over tack welds without problems, and without losing the track. The guide wheel bogey is secured to the contact tube, and the welding nozzle is positioned to weld behind the guide wheel bogey. See chapter "ACCESSORIES".

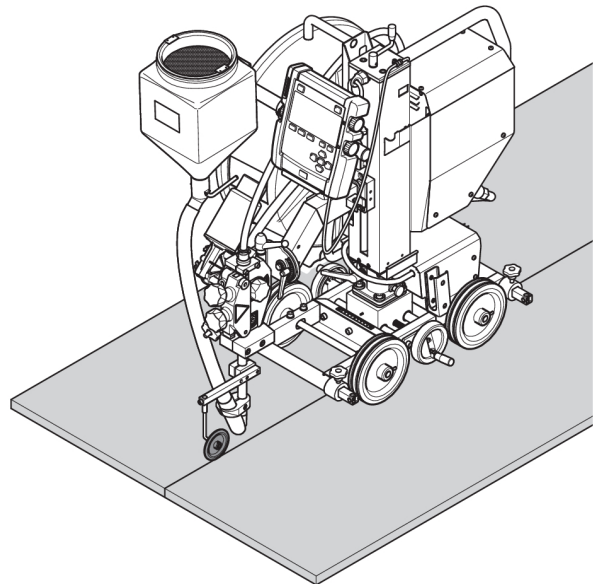

Grooved wheels (0443 682 881)

If there is no suitable edge along which to steer the welding tractor, as when making an I-joint, it can be fitted with two grooved wheels, which will run on an angle iron guide rails can be joined together to make up the required length.

See chapter "ACCESSORIES".

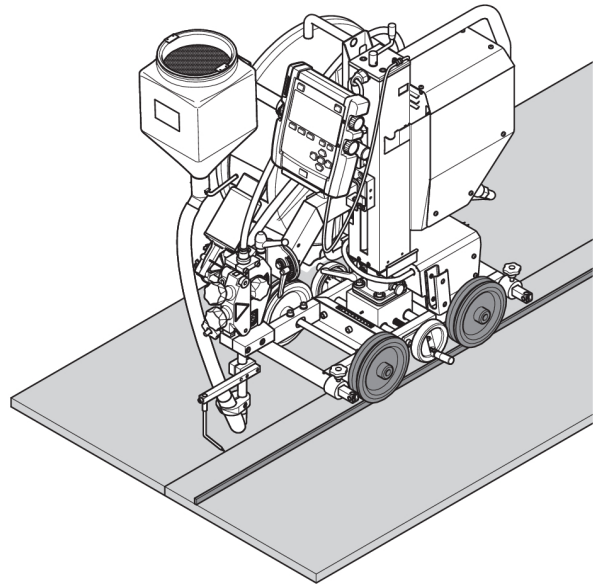

Flat fillet welding (0904 586 880)

The flat fillet welding kit can be used to keep the equipment straight upwards when welding a tilted fillet joint.

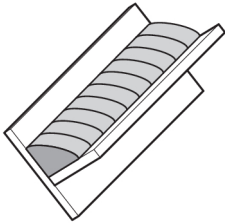

The angle can be set to 0, 30° and 45°.

See chapter "ACCESSORIES".

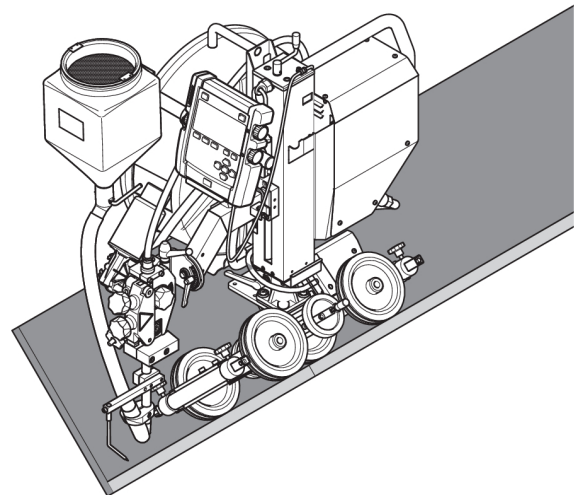

Three wheeler module (0904 557 880)

Used for internal joint welding. The welding tractor follows a guide wheel bogey which is placed in a V-joint.

Minimum pipe diameter for internal joint welding 1.1 m (3.6 ft).

See chapter "ACCESSORIES".

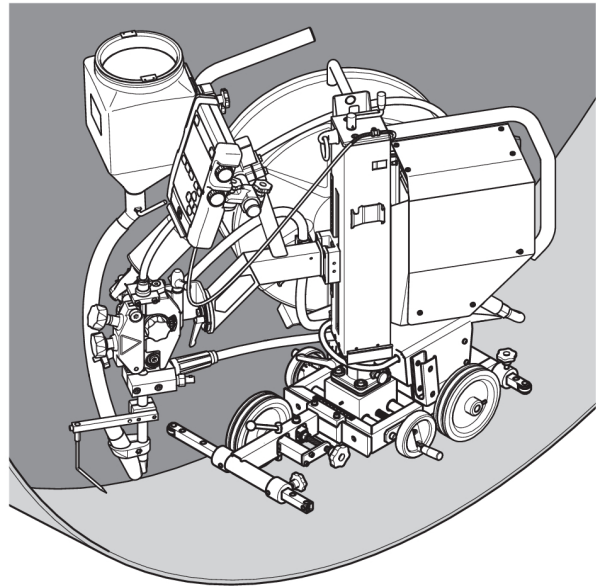
**WARNING!**

To prevent overturning, always keep welding head within the allowed welding area.

The welding area depends on the mounted equipment, as shown in the image.

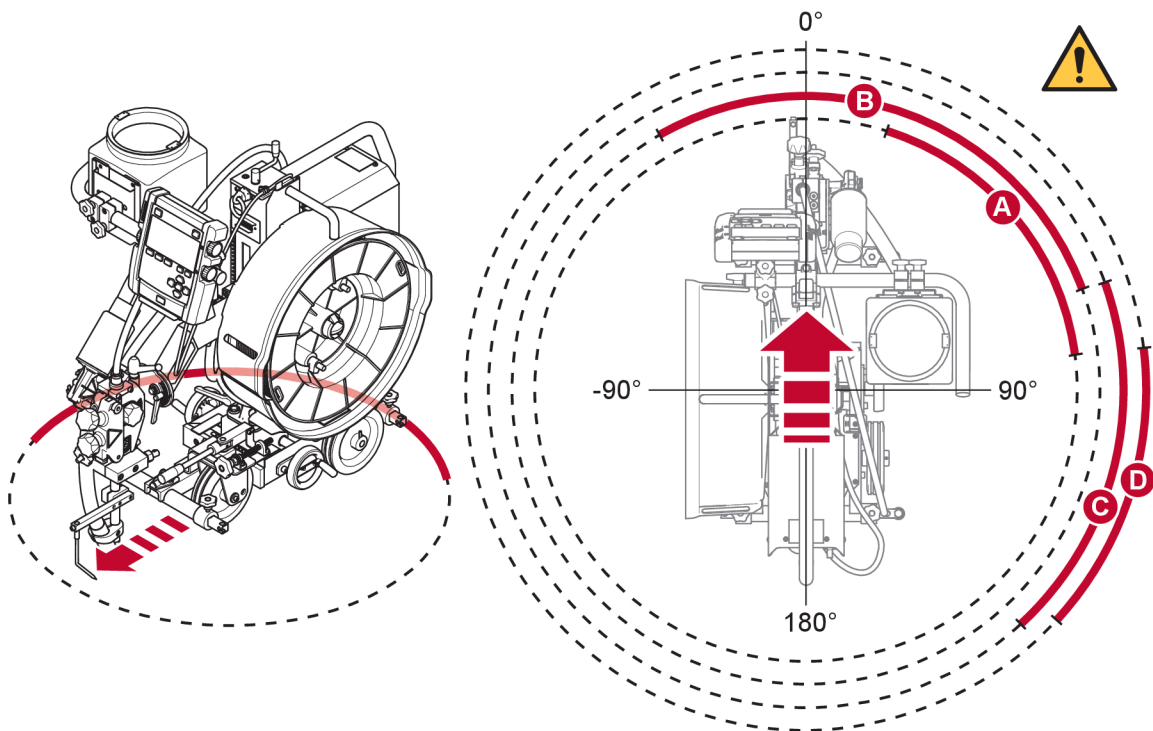

- A. No flux, no wire: Welding head **not** within 17–82.5°
- B. Only flux: Welding head **not** within 30–70°

- C. Only wire: Welding head **not** within 70–137.5°
- D. Both flux and wire: Welding head **not** within 82.5–133°

6 MAINTENANCE

6.1 General

**CAUTION!**

All warranty undertakings from the supplier cease to apply if the customer attempts any work to rectify any faults in the product during the warranty period.

**NOTE!**

Before doing any kind of maintenance work, make sure the mains cable is disconnected.

For maintenance of the control unit, **EAC 10**, and welding heads **EWH**, see separate instruction manual.

6.2 Daily

- Make sure the column is in locked position.
- Make sure the welding head arm is in locked position.
- Make sure that the bobbin holder is in locked position.
- Clean flux and dirt off moving parts.
- Clean flux and dirt off slides.
- Check:
 - The rotation lock between the carriage and the column.
 - The welding head lock.
 - The bobbin holder lock.
- Check that the contact tip and all electrical cables are connected.
- Make sure all screwed joints are tightened.
- Check that guides and drive rollers are not worn or damaged.
- Check the brake hub braking torque. Tighten if the wire reel continues to rotate when the wire feed is stopped. Loosen if the feed rollers slip. As a guide, the braking torque for a 30 kg wire reel should be 1.5 Nm.
To adjust the braking torque, see section "Adjusting the brake hub".

6.3 Weekly

- Inspect the slides. Lubricate them, if they are binding.

7 TROUBLESHOOTING

Perform these checks and inspections before sending for an authorised service technician.

7.1 EWT 1000

Type of fault	Possible cause	Action
No travel motion	Poor electrical connection.	Clean and tighten all electrical connections.
		Check cables.
Incorrect motor speed	Error in encoder. No feedback in the system.	Clean and tighten all electrical connections.
		Check cables.

7.2 EAC 10

Type of fault	Possible cause	Action
Control unit does not start, diode not lit	42 V missing.	Check the electrical connections.
		Check control cable.
		Check if On/Off switch is in the right position (analogue/digital).
Control pendant does not start	12 V missing.	Check the electrical connections.
		Check cable.

8 ERROR CODES

Error management codes are used to indicate that an error has occurred in the welding process. It is indicated in the display via a pop-up menu.

This manual describes the error codes for the EAC 10. The error codes for other units are described in the manuals for these units.



NOTE!

This is valid only for a fully assembled Versotrac EWT 1000 connected to a welding power source.

Error code		Description
LAF, TAF	Aristo® 1000	
6	4201, 4202, 4203	<p><i>High temperature</i></p> <p>The power source has overheated and cancels welding. Welding is permitted again when the temperature falls below the maximum temperature parameter.</p> <p>Action: Check that the cooling air inlets or outlets are not blocked or clogged with dirt. Check the duty cycle being used, to make sure that the equipment is not being overloaded. If the error persists, send for a service technician.</p>
7		<p><i>Low welding current</i></p> <p>The weld arc has been shut down due to too low welding current during the welding process.</p> <p>Action: Is reset at next weld start. If the error persists, send for a service technician.</p>
8		<p><i>Low battery voltage</i></p> <p>Battery voltage too low. If the battery is not replaced, all stored data will be lost. This error does not disable any functions.</p> <p>Action: Send for a service technician to replace the battery.</p>
11	8411 sub-code 0	<p><i>Speed error on a motor, (wire feed, travel motor)</i></p> <p>A motor cannot maintain its speed. Welding stops.</p> <p>Action: Check that the wire feed has not jammed or runs too fast. If the error persists, send for a service technician.</p>
12	12, 93	<p><i>Internal communication error (warning)</i></p> <p>The load on the system's CAN-bus is temporarily too high. The power source may have lost contact with the control unit.</p> <p>Action: Check that all the equipment is correctly connected. If the error persists, send for a service technician.</p>

Error code		Description
LAF, TAF	Aristo® 1000	
14	14, 95	<p><i>Communication error</i></p> <p>The system's CAN-bus has temporarily stopped working due to the load being too high. The current welding process stops.</p> <p>Action: Check that all the equipment is correctly connected. Turn off the mains power supply to reset the unit. If the error persists, send for a service technician.</p>
17	8117	<p><i>Lost contact with the unit</i></p> <p>Action: Check wiring and the connector between the control unit and power source. If the error persists, send for a service technician.</p>
	32	<p><i>No gas flow</i></p> <p>Start prevented.</p> <p>Action: Check the gas valve, hoses and connectors.</p>
43	71	<p><i>High welding current</i></p> <p>Power source have switched off the welding process because the current has exceeded the maximum current parameter for the power source.</p> <p>Action: Is reset at next weld start. If the error persists, send for a service technician.</p>
44	100	<p><i>Start pause welding current</i></p> <p>The welding process has stopped because it has not advanced within 10 seconds.</p> <p>Action: Is reset at next weld start. If the error persists, send for a service technician.</p>
168, 169	8411 sub-code 1	<p><i>A motor has stopped.</i></p> <p>There are no pulses from the motor pulse transducer.</p> <p>For LAF and TAF: 168 = Motor M1 (Wire feeder motor), 169 = Motor M2 (Travel motor)</p> <p>Action: Check the motor cables. Replace the pulse transducer.</p>
	2310	<p><i>Current servo saturation</i></p> <p>The power source has temporarily delivered maximum current.</p> <p>Action: If the error persists, try lowering the weld data.</p>
4	3205	<p><i>High DC voltage</i></p> <p>Action: Check if the main voltage is too low or too high.</p>
88	5010	<p><i>High inductance</i></p> <p>Inductance is too high, depending on long welding cables and/or high weld data.</p> <p>Action: Try adjusting the weld data.</p>

9 ORDERING SPARE PARTS



CAUTION!

Repair and electrical work should be performed by an authorised ESAB service technician. Use only ESAB original spare and wear parts.

The Versotrac EWT 1000 Chassis is designed and tested in accordance with international and European standards **IEC/EN 60974-5**, **IEC/EN 60974-10** and **EN 12100:2010**. On completion of service or repair work, it is the responsibility of the person(s) performing the work to ensure that the product still complies with the requirements of the above standard.

Spare parts and wear parts can be ordered through your nearest ESAB dealer, see esab.com. When ordering, please state product type, serial number, designation and spare part number in accordance with the spare parts list. This facilitates dispatch and ensures correct delivery.

DIAGRAM

Digital power source

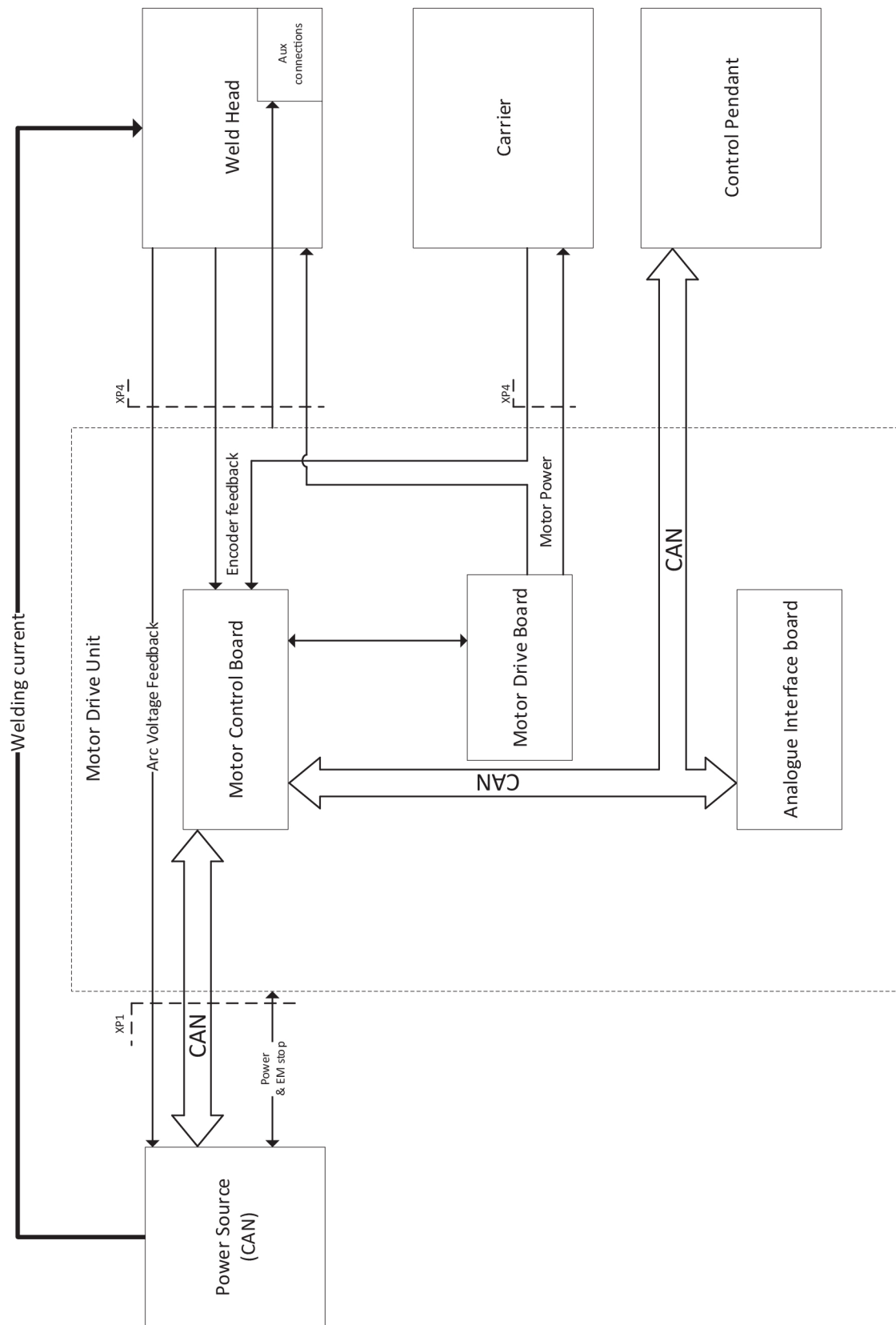

Analogue power source

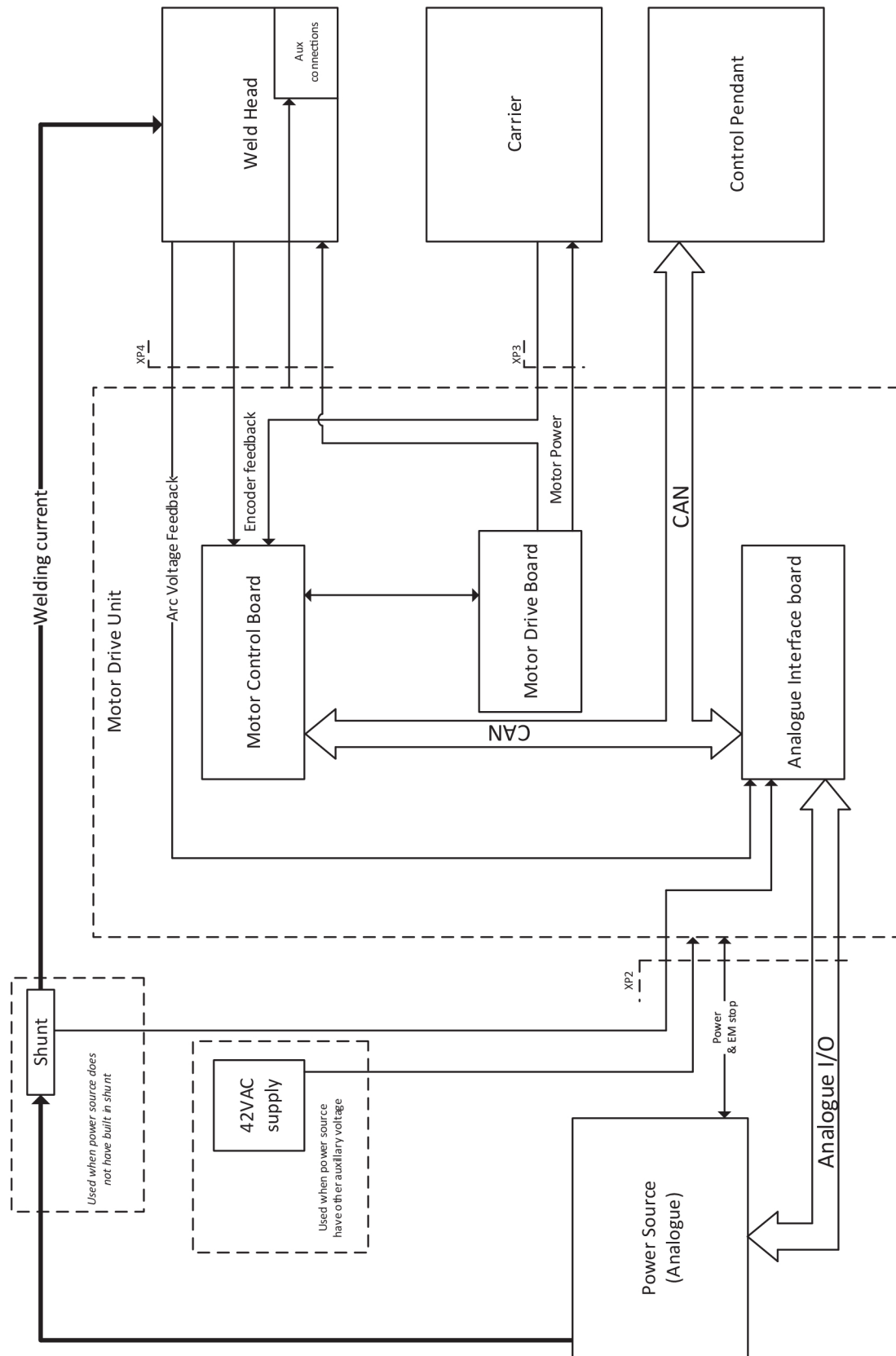

ORDERING NUMBERS

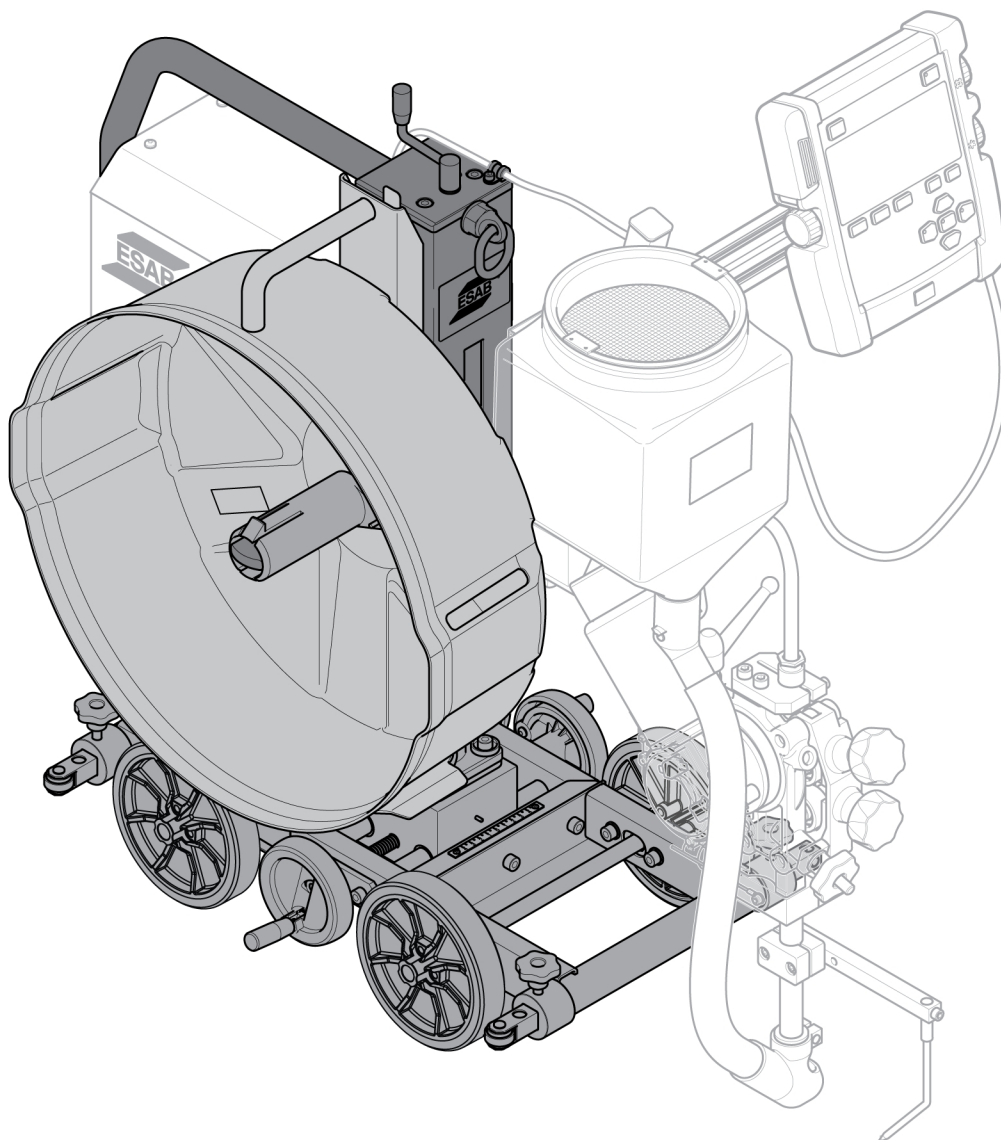

Ordering number	Denomination	Type	Notes
0904 200 891	Welding tractor	Versotrac EWT 1000 Chassis, 4WD	Welding heads and Bobbin holder available separately.
0463 614 001	Spare parts list		



Technical documentation is available on the Internet at: www.esab.com

The three last digits in the document number of the manual show the version of the manual. Therefore they are replaced with * here. Make sure to use a manual with a serial number or software version that corresponds with the product, see the front page of the manual.

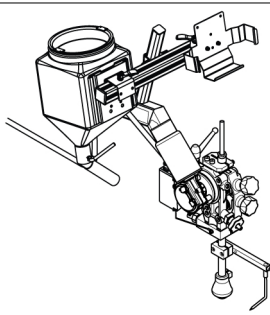
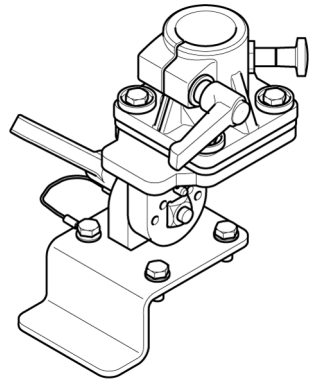
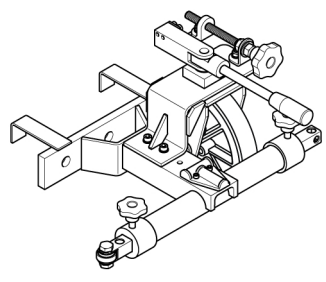
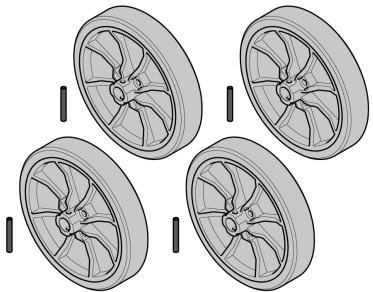
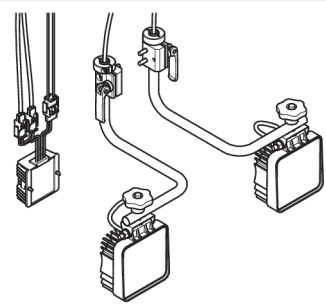
ACCESSORIES

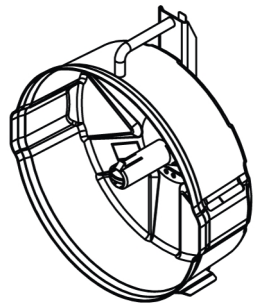
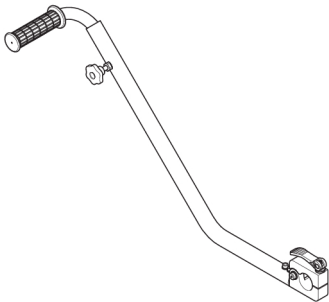
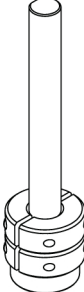
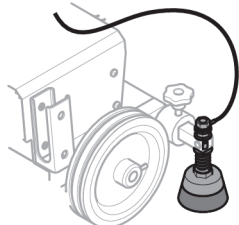
EWT 1000		
0904 520 880	Welding head, EWH 1000 Single	
0904 520 884	Welding head, EWH 1000 Twin Requires two Portable Wire Bobbin Holders - 0908520880	
0904 520 885	Welding head, EWH 600 GMAW	
0908 904 880	Gouging head, EWH 1600 Gouging	
0904 586 880	Flat fillet welding kit	
0904 557 880	Three wheeler module	
0910 531 880	Wheel kit	
0904 273 880	LED lamp kit, 27 W, 12/24 V	

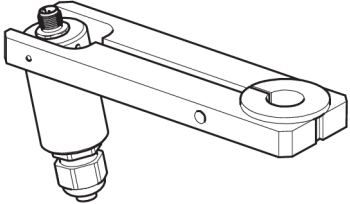
EWT 1000		
0908 520 880	Bobbin holder	
0904 537 880	Steering handle	
0446 151 880	Idling roller (1 piece)	
0443 682 881	V-wheeltrack steel (4 pcs)	
0443 682 880	V-wheeltrack steel (1 piece)	
0332 947 880	Bracket suction	
0904 223 880	Work piece voltage reference brush	
0413 542 880	Guide wheel bogey. For V-joints, used for joint tracking, for fitting on the contact tube.	
0415 857 002	Heat resistant wheel (1 piece), 250 °C (482 °F)	
0154 203 880	Guide rail with magnets, 3 m (9.8 ft). Several lengths of guide rail can be used.	

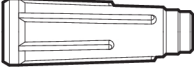
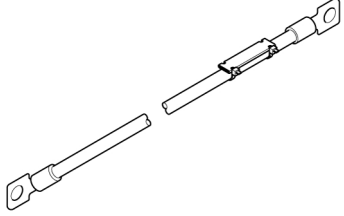

EWH 1000		
0821 440 984	Laser lamp kit, 0.5 m (1 ft 7.7 in.) cable	
0160 360 882	OKC connector Male, 70-120 mm²	
0160 361 882	OKC connector Female, 70-120 mm²	
Welding cable with OKC		
0446 134 880	95 mm ² , 15 m (49 ft)	
0446 134 881	95 mm ² , 25 m (82 ft)	
0446 134 882	95 mm ² , 35 m (115 ft)	
0446 134 883	95 mm ² , 50 m (164 ft)	
0446 134 884	95 mm ² , 75 m (246 ft)	
0446 134 885	95 mm ² , 100 m (328 ft)	
0446 134 890	120 mm ² , 15 m (49 ft)	
0446 134 891	120 mm ² , 25 m (82 ft)	
0446 134 892	120 mm ² , 35 m (115 ft)	
0446 134 893	120 mm ² , 50 m (164 ft)	
0446 134 894	120 mm ² , 75 m (246 ft)	
0446 134 895	120 mm ² , 100 m (328 ft)	
0810 093 880	Flexible arm	
0148 140 880	Flux recovery unit OPC	
0413 315 881	Flux hopper of silumin alloy	
0145 221 881	Concentric flux feeding funnel	
Contact tube		
0413 510 001	260 mm (10.24 in.)	
0413 510 002	190 mm (7.48 in.)	
0413 510 003	100 mm (3.94 in.)	
0413 510 004	500 mm (1 ft 7.7 in.)	
0413 511 001	Contact tube, bent	

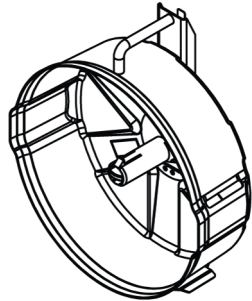
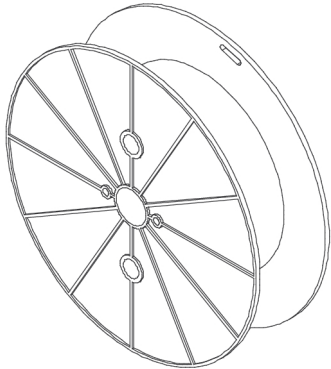
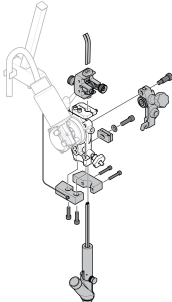
ACCESSORIES

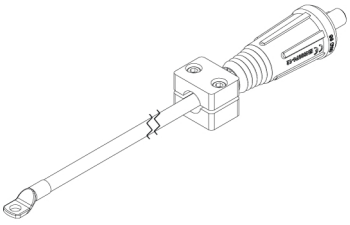
0908 520 880	Bobbin holder	
0153 872 880	Wire reel, plastic, 30 kg	
0449 125 880	Wire reel, steel, flexible width	
0671 164 080	Wire reel, steel Ø 220 mm	
0446 110 880	Single to twin conversion kit	

Gouging cables with OKC (For gouging head)		Maximum Current A	Required Qty¹⁾	
0908 778 880	95 mm ²	1000	2	
0908 778 881	120 mm ²	630	1	
		1250	2	
		1600	3	

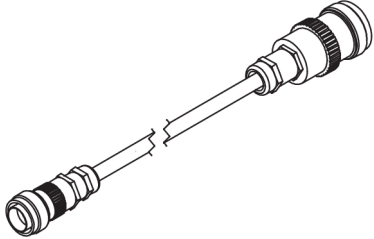
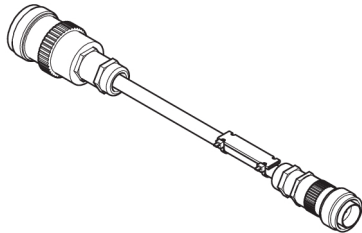
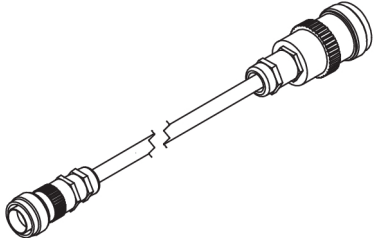
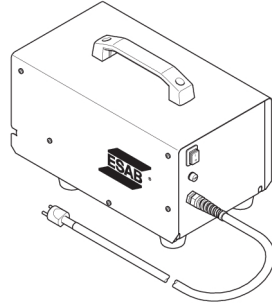
¹⁾ The number of cables needed for proper and safe function at the specified maximum current. The cables are ordered by piece.

EAC 10		
Control cable EAC 10 - digital power source		
0460 910 880	5 m (16 ft)	
0460 910 881	15 m (49 ft)	
0460 910 882	25 m (82 ft)	
0460 910 883	35 m (115 ft)	
0460 910 884	50 m (164 ft)	
0460 910 885	75 m (246 ft)	
0460 910 886	100 m (328 ft)	
Control cable EAC 10 - digital power source and work piece voltage reference brush		
0446 146 880	5 m (16 ft)	
0446 146 881	15 m (49 ft)	
0446 146 882	25 m (82 ft)	
0446 146 883	35 m (115 ft)	
0446 146 884	50 m (164 ft)	
0446 146 885	75 m (246 ft)	
Control cable EAC 10 - ESAB analogue power source		
0449 500 880	15 m (49 ft)	
0449 500 881	25 m (82 ft)	
0449 500 882	35 m (115 ft)	
0449 500 883	50 m (164 ft)	
0449 500 884	75 m (246 ft)	
0449 500 885	100 m (328 ft)	
Welding power source interface, for non-ESAB analogue SAW power source		
0446 180 880	115 V version	
0446 180 881	230 V version	
0462 062 001	USB Memory stick 2 Gb	

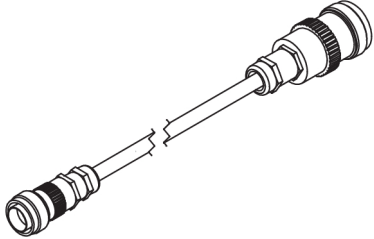
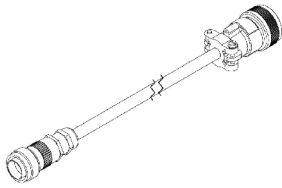
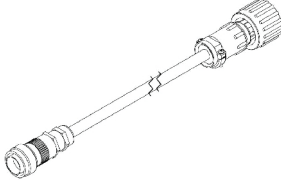
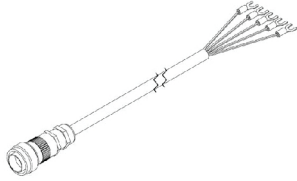
Welding power source interface		
Control cable EAC 10 - Welding power source interface		
0446 179 880	15 m (49 ft)	
0446 179 881	25 m (82 ft)	
0446 179 882	35 m (115 ft)	
0446 179 883	50 m (164 ft)	
0446 179 884	75 m (246 ft)	
0446 179 885	100 m (328 ft)	
Control cable for welding power source interface - general analogue controlled power source		
0446 157 880	Cable with 14-pin MS3106 20-27PX plug Suitable for power sources: <ul style="list-style-type: none"> • Lincoln Flextec 650/650x • Lincoln DC 600 • Lincoln DC 655 	
0446 156 880	Control cable 14-pin, CPC type Suitable for power sources: <ul style="list-style-type: none"> • Miller dimension 650, 652, 452 	
0446 178 880	Control cable, terminal block Suitable for power sources: <ul style="list-style-type: none"> • Miller SubArc DC 650, 800, 1000, 1250 • Lincoln DC 1000 	



A WORLD OF PRODUCTS AND SOLUTIONS.



For contact information visit esab.com

ESAB AB, Lindholmsallén 9, Box 8004, 402 77 Gothenburg, Sweden, Phone +46 (0) 31 50 90 00

manuals.esab.com

